

Ym1	YM2	Ym3	Siding
Red	Red	Red	A
Green	Red	Red	B
Green	Green	Red	C
Green	Green	Green	D

Alternating 3 train siding with a pass thru Main line

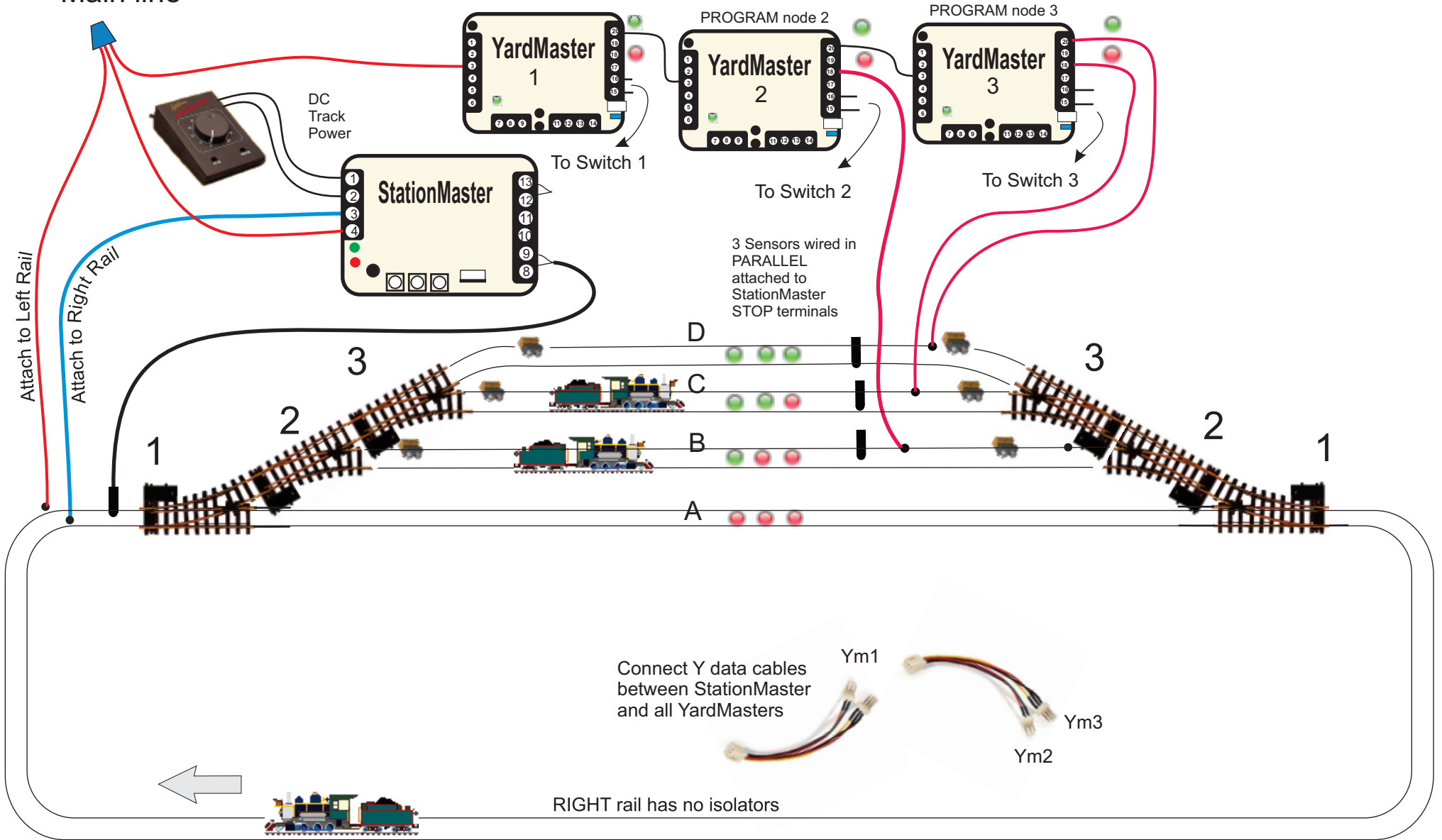

Connect Y data cables between StationMaster and all YardMasters



Place MAGNET on bottom of all engines.



Parts required:

- StationMaster Qty 1
- YardMaster: Qty 3
- Sensors: Qty 4
- Turnouts: Qty 6 ... 3 are powered.
- Track Isolators: Qty 6
- Magnets: Qty 3, One for each train.

Description:

This hookup will allow one train to perform multiple laps on the main line. After the lap count is done that train will park itself in a siding. After a delay the adjacent train will accelerate and enter the main line and repeat. 3 trains will alternate running.

Hookup Description:

YardMaster #1:

- Terminal #3 attaches to the StationMaster pin 4.
- Terminals #15 and #16 attach to switch #1.
- Terminal #20 attaches to YardMaster 1 terminal #3
- Programming: None. (Perform a factory reset)

YardMaster #2:

- Terminal #3 attaches to YardMaster 1 Terminal #20.
- Terminals #15 and #16 attach to switch #2.
- Terminal #18 attaches to isolated left rail of siding B.
- Terminal #20 attaches to pin 3 of YardMaster #3
- Programming: Set for Node #2 (3 blinks)

YardMaster #3:

- Terminal #3 attaches to YardMaster 2 Terminal #20.
- Terminals #15 and #16 attach to switch #3.
- Terminal #18 attaches to isolated left rail of siding C.
- Terminal #20 attaches to isolated left rail of siding D
- Programming: Set for Node #3 (4 blinks).

StationMaster

Terminals 8 and 9 attach to DECEL sensor. Note: this sensor must be placed before the first turnout far enough away to allow the turnout to switch before the train enters the siding.

Terminals 12 and 13 attach to all STOP sensors wired in parallel in the sidings.

Terminals 3 and 4 attach to the track. Terminal 4 is Left rail positive which also goes to YardMaster terminal 3, StationMaster terminal 3 is Right Rail common throughout.

Terminals 1 and 2 attach to input power source. (12 to 20 volts) Set the transformer speed to the desired train speed. (2 is common, 1 is positive)

Programming:

- Train count = 4,
- Decel rate = INFINITE,
- Lap count > 2
- Time Delay as desired and Accel rate as desired.

Notes:

The direction of the trains is shown in the diagram. Set the transformer direction so that the StationMaster powers up. Set transformer speed to top speed of the train. If the switches do not reliably fire turn up the transformer speed and turn down the top speed dial on the StationMaster to set the top speed of the train.

Each train must carry a magnet to trigger the sensors.

The exit switches can be either powered and wired in parallel with the entry switches or floating with the trains pushing the points.

The LEFT rail of each siding is isolated and attached to a YardMaster.

Right rail is "ground" and is connected to all sidings without isolators.

YardMasters will fire in sequence. Swap the wires to switches as required so that the switch is lined up to the proper siding as shown in the table on page 3.

Alternating 3 train siding with a pass thru Main line

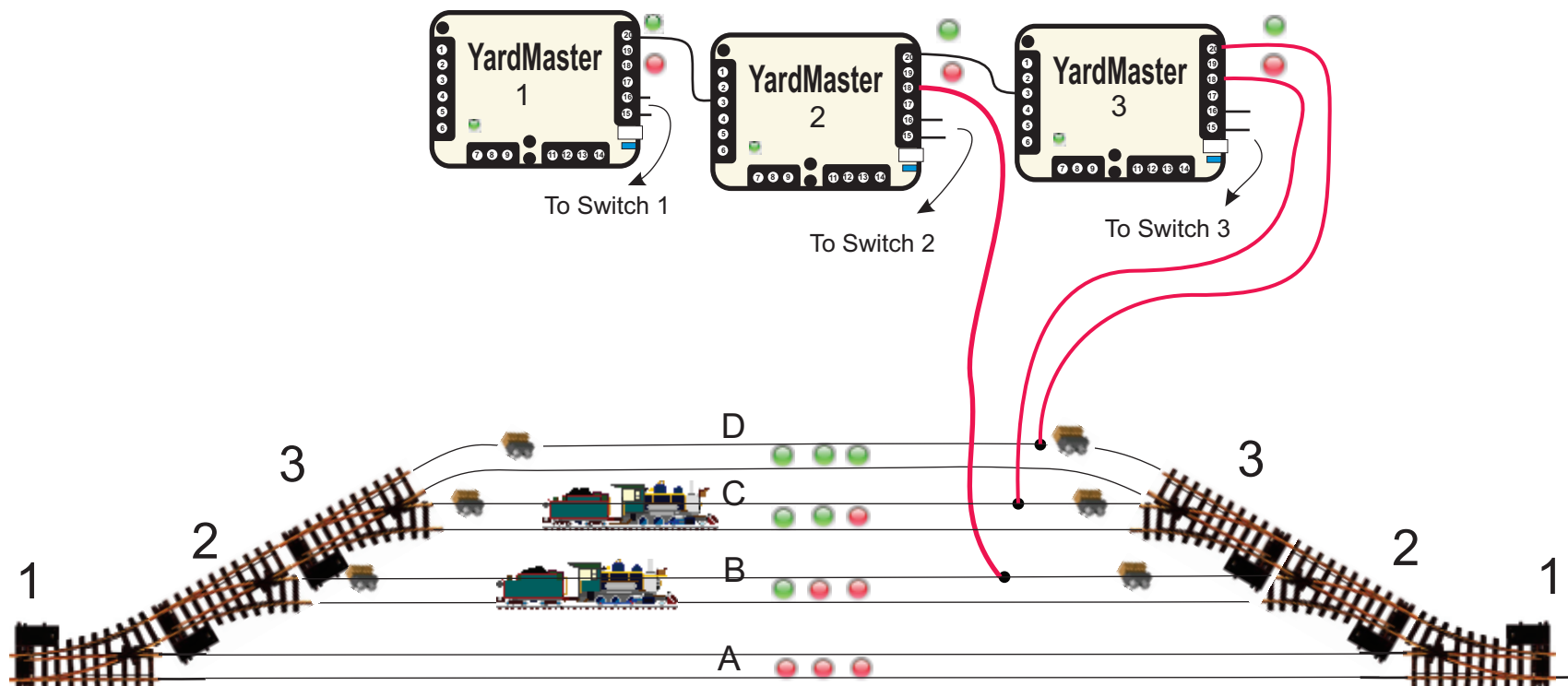

Turnout Connections

Connecting turnouts to YardMasters is done by “trial and error”. First attach the wires to the turnouts and then swap the polarity on the turnouts as needed. With the power on push the alternate button on the YardMasters to change the YardMaster colors from red to green.

Turnout #1: When YardMaster #1 is RED turnout #1 should switch to straight which is the main line “A” siding..

Turnout #2: When YardMaster #2 is RED turnout #2 should be set to curve which is the “B” siding.

Turnout #3: When YardMaster #3 is RED turnout #3 should be set to curve which is the “C” siding.

Operating Notes:

When the StationMaster is counting laps it will have an ORANGE indication. When orange the DECEL sensor will fire turnout #1 to the main line. After the programmed number of laps have expired the DECEL sensor will fire to the appropriate siding and stop the train. Make sure the DECEL sensor is placed a few inches before turnout #1 so it has time to fire before the train goes through the turnout.